



## Enviro-Dri™ Weather-Resistant Barrier (WRB) System Installation Instructions

Revised 02.12.10

### General:

The purpose of the Enviro-Dri™ Weather Resistant Barrier (WRB) System, by Tremco Barrier Solutions Inc., (TBS), is to coat and seal the exterior surface of the sheathing to protect the sheathing material from detrimental environment effects prior to installation of the exterior cladding and to prevent the passage of exterior water through the Enviro-Dri WRB System for the service life of the building, while allowing the transmission of excess water vapor. If the recommended treatment of window and door openings is followed, along with other sound building practices, the Enviro-Dri WRB System will serve as a valuable component in the effort to reduce air infiltration and exfiltration to acceptable levels.

The Enviro-Dri WRB System is an approved water-resistive barrier, as specified in section 1404.2 of the 2006 International Building Code and section R703.2 of the 2006 International Residential Code, for application to plywood, oriented strand board, and impregnated fiberboard (blackboard\*) sheathing.

All exterior surfaces of the sheathing should be coated and the joints between individual elements of the sheathing should be sealed. The exterior surface of the sheathing is to be fully coated with Enviro-Dri Field Membrane or Enviro-Dri Joint Sealant so that none of the sheathing can be seen through the applied Enviro-Dri WRB System materials. This is more easily checked after the applied materials have dried. The Enviro-Dri Field Membrane is to be applied at a minimum thickness of 12 wet mils measured in-place on the wall with an ASTM D4414 notch film gauge. A typical thickness range is 12-15 wet mils, which yields a coverage rate  $120 \pm 15$  ft<sup>2</sup> per gallon. Joints between the sheathing panels should be sealed with Enviro-Dri Joint Sealant. Details of the sealing requirements are contained in the System Application section. It is normal for the Enviro-Dri Joint Sealant to contract in volume as it cures, and as a result the entire cross section of a joint may not be filled after curing. The entire joint cross section need not be fully filled with material for the joint to be sealed, figures 1a and 1d.

Joints may also be sealed by using Enviro-Dri Joint Fabric, fully coated with either Enviro-Dri Field Membrane or Enviro-Dri Joint Sealant and continuously adhered to the exterior sheathing surface on both sides of the joint. This is can be particularly useful for gaps exceeding ¼" in width, but it is not required, figures 1c and 1e. See 'Surface/Site Preparation' for additional detail on treatment of joints in excess of ¼."

### **Enviro-Dri WRB System Materials from TBS:**

- Enviro-Dri Field Membrane, vapor-permeable field membrane emulsion
- Enviro-Dri Joint Sealant, high viscosity joint sealant emulsion
- Enviro-Dri Counterflashing Fabric, counter flashing fabric
- Enviro-Dri Joint Fabric, joint sealing fabric

Do not dilute or add any foreign materials to the Enviro-Dri WRB System emulsion products. Do not substitute any other fabrics for the Enviro-Dri WRB System fabrics.

\*In AC212 Tensile Bond Testing, the tensile adhesion of the Enviro-Dri material exceeded the internal strength of the blackboard sheathing, which was lower than 15 psi.

## **Material Storage and Handling:**

### ***Storage***

Enviro-Dri Field Membrane and Enviro-Dri Joint Sealant are specially formulated asphalt-based emulsions; they are water-based with low VOC content. Like all water-based emulsions, they must be kept from freezing. Enviro-Dri Field Membrane and Enviro-Dri Joint Sealant should be stored off the floor at an ambient temperature above 50 °F (10°C). Opened drums should be tightly sealed before storage to avoid a skin developing on top of the liquid. When shipping emulsion-based products during the winter months, there is always a risk of the material freezing while in transport. The risk is much higher on shipments of less than 40 drums because these shipments go as “less than truckload” and do not go directly from the TBS warehouse to your location. If you suspect that material you received has frozen during shipment, evidenced by an unusual appearance of the product, contact your TBS Technical Representative or Territory Manager.

Maximum storage temperature shall not exceed 100°F (38°C), and product containers should not be exposed to direct sunlight. Minimum storage temperature shall not be less than 40°F (4°C).

### ***Safety***

Use the following safety instructions when handling Enviro-Dri Field Membrane and Enviro-Dri Joint Sealant. Also review the Material Safety Data Sheets (MSDS), as well as the safety precautions provided by application equipment manufacturers.

1. Avoid direct contact with the material. Prolonged or repeated contact can cause skin irritation. If prolonged contact is anticipated, impervious gloves should be worn.
2. Enviro-Dri Field Membrane and Enviro-Dri Joint Sealant emulsions will not support sustained combustion, and will not burn under normal circumstances. (If all water has been evaporated and the product is heated in a confined space, sufficient vapors could accumulate and flash if a source of ignition is present.)
3. If contact with eyes occurs, flush with large amounts of cool water while holding eyelids open. Get medical attention if irritation persists.
4. If spray equipment is used, mist from spray application in a confined area can cause headaches, nausea, and irritation of the nose, throat and lungs. To prevent this, a NIOSH approved respirator for ammonia should be worn. If you begin to smell ammonia through the mask, replace the cartridges.
5. If spray equipment is used, protect the eyes from contact with high-pressure spray; wear chemical safety glasses with side shields.
6. The use of extension poles or ladders made from aluminum or other electrically conducting materials may expose the user to electrical shock hazards, including but not limited to those presented by overhead wires, installed wiring, or lightning. The proper caution and safety procedures regarding these hazards should be followed. Electrically conducting equipment purchased from TBS should not be used during electrical storms, or when other non-mitigated hazards for electrical shock exist.

## **Application Conditions:**

### ***Weather***

The Enviro-Dri WRB System can be applied in a broad range of weather conditions. Any weather condition that allows the installer to achieve a properly-cured, finished, coated and sealed Enviro-Dri WRB System that isn't damaged by subsequent precipitation or moisture condensation is permissible. It is the end result that that should be evaluated. If the end result is a fully cured system, with complete coverage of the sheathing with the proper thickness of Enviro-Dri Field Membrane and proper sealing of the joints between sheathing panels the weather was acceptable.

The air and surface temperatures at the time of application are permitted to be between 0°F (-18°C) and 130°F (54°C). The Enviro-Dri WRB System should not be installed during rain or impending rain that might damage the system before it can sufficiently dry and cure. The substrate must be sufficiently dry to achieve a quality application; see “Substrate check” below. The experience of the installer is the best guide to when the weather is suitable; he is responsible to achieve the properly cured, coated and sealed system.

### ***Cure Time***

Generally, both Enviro-Dri Field Membrane and Enviro-Dri Joint Sealant dry quickly to the touch when applied to approved substrates in the appropriate condition. At 70°F (21°C) and 50% RH they are dry to the touch within 2-4 hours. Generally, cool or damp conditions will slow drying, while hot or dry conditions will accelerate drying. Enviro-Dri Joint Sealant will normally take longer to dry than Enviro-Dri Field Membrane because it is generally applied in a thicker application. Drying time will vary with substrate and individual job conditions.

When the temperatures are below freezing, the Enviro-Dri WRB System can be installed but will freeze before it is fully dry and cured. The freezing does not damage the installation; it will continue to “freeze-dry” in place resulting in a dry and cured system. However, if there is a change from below freezing weather to above freezing weather with rain, there is potential for the rain to damage those portions of the application that are not yet sufficiently cured. In these circumstances, it is the responsibility of the application contractor to insure that the Enviro-Dri WRB System is protected from such damage until it is sufficiently cured.

### ***Exposure***

The Enviro-Dri WRB System should not be left exposed more than 120 days prior to being covered with the exterior cladding material. Enviro-Dri Field Membrane or Enviro-Dri Joint Sealant, when left exposed to UV conditions, may exhibit minor surface cracking, also known as ‘crazing’. This condition is normal and expected, and is cosmetic only. It has no significant effect on the performance of the products.

Care should be taken to prevent water or condensation on the unprotected inside surface of sheathing. Internal moisture from temporary heaters, inadequate roof cover, concrete foundations and floors are sources of internal moisture that can be detrimental to sheathing, even when protected with the Enviro-Dri WRB System on the outside.

## **Pre-Application, Application, and Post-Application:**

### ***Substrate Check***

- Ensure that the substrate is a type listed in the TBS Enviro-Dri WRB System Specification, and approved by the local code authority for use with the TBS Enviro-Dri WRB System.
- Ensure that the sheathing is structurally sound, complete, securely fastened, free of loose material, voids, projections, or other conditions that may interfere with the application of the Enviro-Dri WRB System.
- Ensure that all rough openings are in place and, if used, wedges to create outward slope on window sills are in place.
- Ensure that the substrate is sufficiently dry. There should be no visible water in any joints, and liquid water should not transfer to your hand as it is rubbed across the exterior surface of the sheathing. Plywood or OSB moisture content shall not exceed 24% as measured by a probe type moisture meter.
- Exterior grade gypsum sheathing facing paper shall not show signs of deterioration and shall be firmly bonded to the core.
- Notify the general contractor and/or builder of any deficiencies. Do not proceed with work until the deficiencies have been corrected.

### ***Surface/Site Preparation***

- The substrate shall be prepared so as to be free of foreign materials such as oil, dust, dirt, paint, wax, water repellents, liquid water, frost, snow, ice, or any other materials that may inhibit adhesion. Loose solid materials, such as dirt or mud, can most often be removed with the aid of a scraper and/or a stiff bristle brush. Other foreign materials may require the use of water or a detergent solution to properly clean the surface. If so, the substrate must be allowed to dry after completion of the cleaning.
- The Enviro-Dri Field Membrane and Enviro-Dri Joint Sealant materials do not require primers for their application to approved substrates.
- Sheathing gaps that exceed ¼ inch (6.4 mm) and larger holes or defects may require special treatment. The exterior sheathing surface with un-backed gaps greater than ¼ inch in width must be covered with Enviro-Dri Joint Fabric. The Enviro-Dri Joint Fabric should be attached using standard construction staples affixed approximately every foot both above and below the sheathing gap. The Enviro-Dri Joint Fabric is subsequently fully coated and adhered to the exterior surface of the sheathing on both sides of the gap with either Enviro-Dri Field Membrane or Enviro-Dri Joint Sealant. Backed gaps greater than ¼ inch in width do not require the use of Enviro-Dri Joint Fabric. However, installers may choose to use Enviro-Dri Joint Fabric on other gaps or holes as a matter of personal preference regardless of backing or joint width. Apply no more Enviro-Dri Joint Fabric than can be fully coated and adhered to the substrate the same day and before any rain.
- Protect surrounding areas, surfaces, and objects that are not receiving WRB System materials during installation of the Enviro-Dri WRB System.

### ***System Application***

- Both the Enviro-Dri Joint Sealant and the Field Membrane can be applied using a brush, trowel, manual roller or power roller or spray equipment over sheathing materials approved in writing by TBS.
- The Enviro-Dri Joint Sealant and the Field Membranes are ready for application as supplied. For applications, the product may be applied as-is or heated. The temperature should be high enough to maintain good application characteristics during cold conditions, but should not exceed 130°F (49°C).
- The sheathing area should be fully and evenly coated with Enviro-Dri Field Membrane applied at a minimum thickness of 12 mils, normally 12-15 mils. The application thickness of the wet coating can be checked using a notch film gauge. This is also the thickness at which a roller is making “chicken tracks” in the coating as it rolls product onto the substrate, figure 5.
- The proper applied thickness results in an approximate coverage rate of  $120 \pm 15$  ft<sup>2</sup> per gallon of the Enviro-Dri Field Membrane material, (0.0085 ± 0.0011 gal/ft<sup>2</sup>). The coverage rate on individual installations will vary due to surface roughness, sheathing condition, and/or other varying conditions.
- Joints between sheathing panels or between sheathing panels and framing materials must be sealed using either Enviro-Dri Joint Sealant alone or using Enviro-Dri Joint Fabric coated with either Enviro-Dri Joint Sealant or Enviro-Dri Field Membrane.
  - When using Enviro-Dri Joint Sealant alone, sheathing panel joints wide enough to be effectively filled with Enviro-Dri Joint Sealant, but narrower than ¼”, may be sealed by filling the joint with Enviro-Dri Joint Sealant material. The full depth of the joint should be filled with the Enviro-Dri Joint Sealant material. After curing, the Enviro-Dri Joint Sealant material should span the joint and have a thickness of at least 2/3 the depth of the joint, figures 1a and 1d. For wider joints that are backed with framing or other material, the joint between the interior edge of the sheathing panel and the backing should be sealed with Enviro-Dri Joint Sealant at a

minimum of ¼ inch thickness, measured as a radius from the joint, figure 1b. This will cure to a thickness exceeding 1/8 inch, figure 1b.

- When using Enviro-Dri Joint Fabric, the entire fabric must be fully coated as well as adhered and totally sealed to the exterior surface of the sheathing on both sides of the joint with either Enviro-Dri Field Membrane or Enviro-Dri Joint Sealant. Sufficient care must be taken to insure that any wrinkles or other irregularities are further treated to the extent that no water or air can penetrate the plane of the exterior sheathing by passing either through or around the coated and sealed Enviro-Dri Joint Fabric. The Enviro-Dri Joint Fabric may be coated and sealed with either Enviro-Dri Joint Sealant or Enviro-Dri Field Membrane.
- All joints less than 1/8 inch in width must use the Enviro-Dri Joint Fabric option.
- Un-backed joints greater than ¼ inch in width must use the Enviro-Dri Joint Fabric option, figure 1e.
- The order of application of Enviro-Dri Field Membrane and Enviro-Dri Joint Sealant materials is discretionary. Enviro-Dri Field Membrane may be applied to the sheathing surface followed by the application of the joint treatment, or the joint treatment may be completed first, followed by application of the Enviro-Dri Field Membrane. For joints using Enviro-Dri Joint Fabric followed by application of Enviro-Dri Field Membrane, only one application of the Enviro-Dri Field Membrane is required and may occur as the majority of the wall area is receiving the Enviro-Dri Field Membrane application.
- It is normal for less than the entire volume of the joint to be filled with Enviro-Dri Joint Sealant. Joints sealed with Enviro-Dri Joint Sealant need not be totally filled to be sealed. For further detail, refer to the joint sealing illustrations.
- It is normal for the Enviro-Dri Joint Sealant material to cover a portion of the face of the sheathing near the joint being sealed. Except for the application to tightly butted sheathing panel joints discussed above, there is no required minimum width of Enviro-Dri Joint Sealant material coating the sheathing surface at the joint, nor is there a requirement for the minimum depth of such coating.
- Any Enviro-Dri Joint Sealant material on the sheathing surface should be smoothed so that it is no thicker than ¼” at any point.
- The coverage of Enviro-Dri Joint Sealant will vary from job to job depending on the average joint width and other job specifics. Generally, installers can expect to use a volume of Enviro-Dri Joint Sealant that is in a range of 25-40% of the volume of Enviro-Dri Field Membrane used on the job. Individual jobs may be outside this range.

## **Penetrations:**

---

### ***Sealing & Flashing***

The Enviro-Dri WRB System, in and of itself, does not seal penetrations through the sheathing exterior, such as those for window and door openings, utilities, electrical fixtures, vents, and so forth. Penetration sealing and flashing is a separate item that should be agreed upon by the application contractor and builder. The builder, at his discretion, may elect to have a subsequent trade install flashing or counterflashing that could potentially have been installed by the Enviro-Dri WRB System application contractor, eliminating the items depicted in figure 2 from the Enviro-Dri WRB System contractor’s scope of work. For example, a roofer could install both flashing and counterflashing where roof sections intersect vertical walls, or window/door installers could install both flashing and counterflashing at the window and door openings. In all cases, TBS recommends following good construction practice with regard to flashing and counterflashing details, shown in-part in illustrations 1-4.

For cases in which the Enviro-Dri WRB System application contractor and builder have agreed that the Enviro-Dri WRB System contractor is responsible for sealing and/or flashing the penetrations through the surface covered by the Enviro-Dri WRB System, the following minimum specifications should be followed or exceeded.

## ***Rough Openings for Windows and Doors***

### ***Alternative 1 – Preferred***

To provide an additional barrier to water entry at window or door openings, due to deficiencies in the external sealing and/or flashing, the inner surface of the jambs and sill should be protected with either Enviro-Dri Joint Sealant or Enviro-Dri Field Membrane. In addition, this method is a significant step in providing a functional air barrier for the building envelope. TBS recommends that all window sills are constructed with an outward slope; the construction providing the outward slope must be in place before the installation of the TBS Enviro-Dri WRB System.

As with all rough openings, Enviro-Dri Counterflashing Fabric is applied at the top of the rough opening so that the bottom edge of the Enviro-Dri Counterflashing Fabric is even with the top of the rough opening and the Enviro-Dri Counterflashing Fabric extends a minimum of 5” beyond the rough opening on each side. Sufficient care must be taken to insure that any wrinkles or other irregularities are further treated to the extent that no water or air can penetrate the plane of the exterior sheathing by passing either through or around the coated and sealed Enviro-Dri Joint Fabric. The Enviro-Dri Joint Fabric may be coated and sealed with either Enviro-Dri Joint Sealant or Enviro-Dri Field Membrane.

In addition, Enviro-Dri Joint Fabric is installed to both jambs and the sill so it wraps onto the exterior surface ½ to 1 inch and extends into the rough opening 3 ½ to 4 inches. Cuts are made in the lower two corners of the opening to facilitate the wrapping onto vertical and horizontal exterior surfaces. The Enviro-Dri Joint Fabric is then fully coated and adhered to the substrate, with either Enviro-Dri Field Membrane or Enviro-Dri Joint Sealant, creating a waterproof seal between the jambs/sill and the sheathing.

### ***Alternative 2 – Permitted***

The Enviro-Dri Field Membrane and Enviro-Dri Joint Sealant materials are applied only to the exterior surface of the sheathing. The joint between the interior of the sheathing and the jamb and sill framing are sealed by application of Enviro-Dri Joint Sealant; the Enviro-Dri Joint Sealant must continue a minimum of 1 inch onto the jamb and sill framing. In addition, the joint between the jamb and sill framing is sealed with Enviro-Dri Joint Sealant or another sealant approved by TBS. Enviro-Dri Counterflashing Fabric is applied at the top of the rough opening so that the bottom edge of the Enviro-Dri Counterflashing Fabric is even with the top of the rough opening and the Enviro-Dri Counterflashing Fabric extends a minimum of 5” beyond the rough opening on each side.

### ***Alternative 3 – Permitted***

The Enviro-Dri Field Membrane and Enviro-Dri Joint Sealant materials are applied only to the exterior surface of the sheathing with no continuation into rough openings. Enviro-Dri Counterflashing Fabric is applied at the top of the rough opening so that the bottom edge of the Enviro-Dri Counterflashing Fabric is even with the top of the rough opening and the Enviro-Dri Counterflashing Fabric extends a minimum of 5” beyond the rough opening on each side.

### **Compatible Materials:**

TBS’ Enviro-Dri WRB System materials are compatible with a broad range of construction materials including but not limited to the following:

#### **Sheathing**

OSB, plywood, impregnated fiberboard (blackboard)

#### **Cladding**

brick, stone, stucco, cementitious siding, vinyl, aluminum, wood

#### **Exterior Insulation in contact with the Enviro-Dri WRB System**

expanded and extruded polystyrene, fiberglass

**Flashing**

galvanized metal, aluminum, painted aluminum, copper, stainless steel, vinyl, butyl rubber or polymer-modified asphalt flashing fabrics.

For all other materials, determination of compatibility is the responsibility of the manufacturer of the material to insure compatibility with the Enviro-Dri WRB System materials and approve its use in conjunction with Enviro-Dri WRB System applications.

**Recommended Application Tools:**

---

For a list of equipment, tools, and supplies commonly used for application of the Enviro-Dri WRB System, contact a TBS Technical Representative or Territory Manager at the address or number given below.

**Damage by Subsequent Trades:**

---

Neither TBS nor any application contractor applying TBS products is responsible for any damage to the Enviro-Dri WRB System or for any consequential damage resulting from damage to the Enviro-Dri WRB System.

**DISCLAIMER**

---

Information contained in these application instructions conforms to standard detail and product recommendations for the installation of the TBS Enviro-Dri WRB System products as of the date of publication of this document and is presented in good faith. Tremco Barrier Solutions, Inc. (TBS) assumes no liability, expressed or implied, as to the architecture, engineering or workmanship of any project. To ensure that you are using the latest, most complete information, contact:

Tremco Barrier Solutions, Inc.  
6402 E. Main Street, Suite 201  
Reynoldsburg, OH 43068  
(614) 322-4420

# Figure 1 - Enviro-Dri™ Joints Sealing Illustrations

## Gaps With Backing

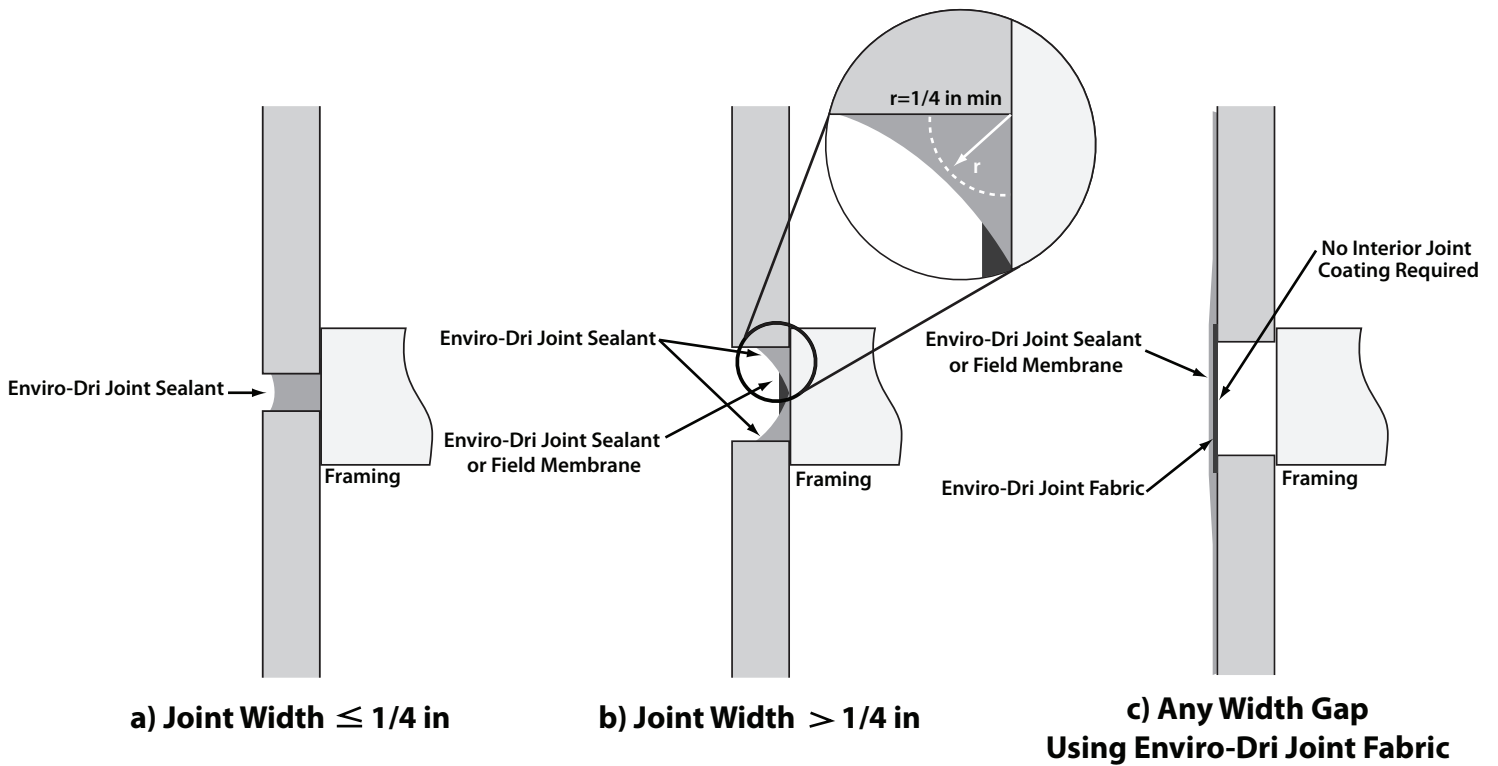

## Gaps Without Backing

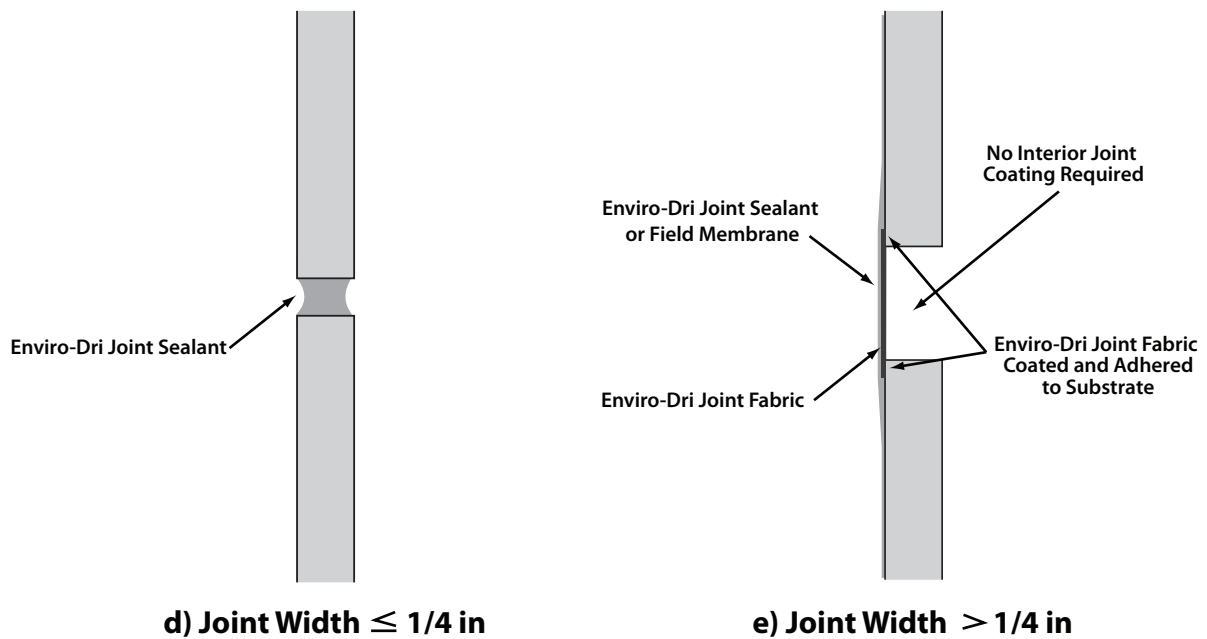



# Tremco Barrier Solutions Enviro-Dri WRB System Flashing Illustrations

Install TBS Enviro-Dri Counterflashing Fabric with the upper portion embedded in the Enviro-Dri Field Membrane in specified locations

1. At the bottom edge of the sheathing, Enviro-Dri Counterflashing Fabric shall be installed so that the lower edge of the Enviro-Dri Counterflashing Fabric is a minimum of 1" below the top of the foundation wall.

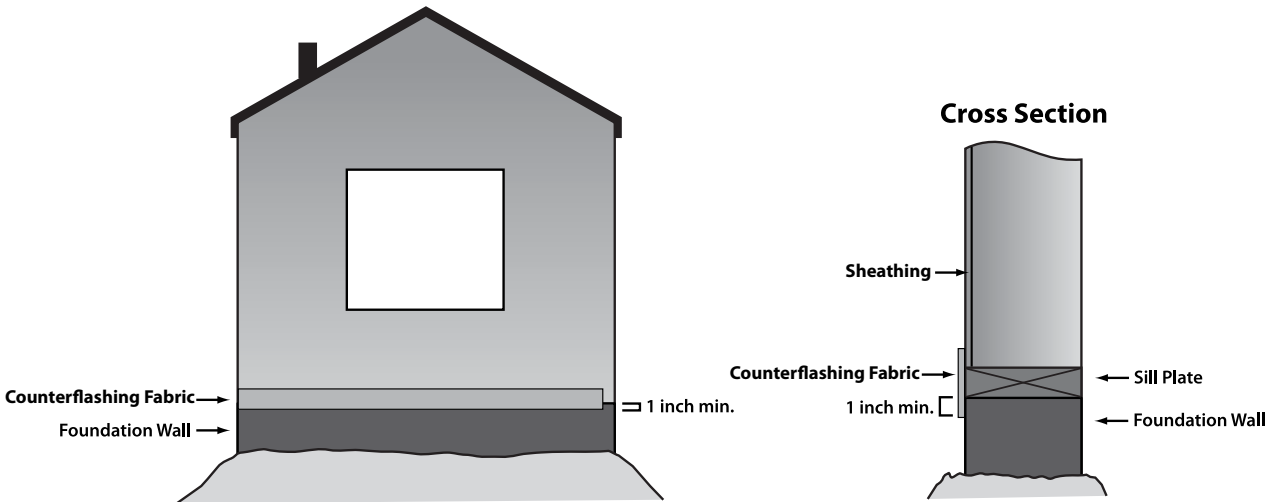

- 
2. Enviro-Dri Counterflashing Fabric shall be installed at the bottom of all wall sections intersecting roof sections to counterflash the continuous flashing or step flashing with the lower edge of the Enviro-Dri Counterflashing Fabric 2" above the roof/ wall intersection and extending a minimum of 4" beyond the flashing as appropriate.

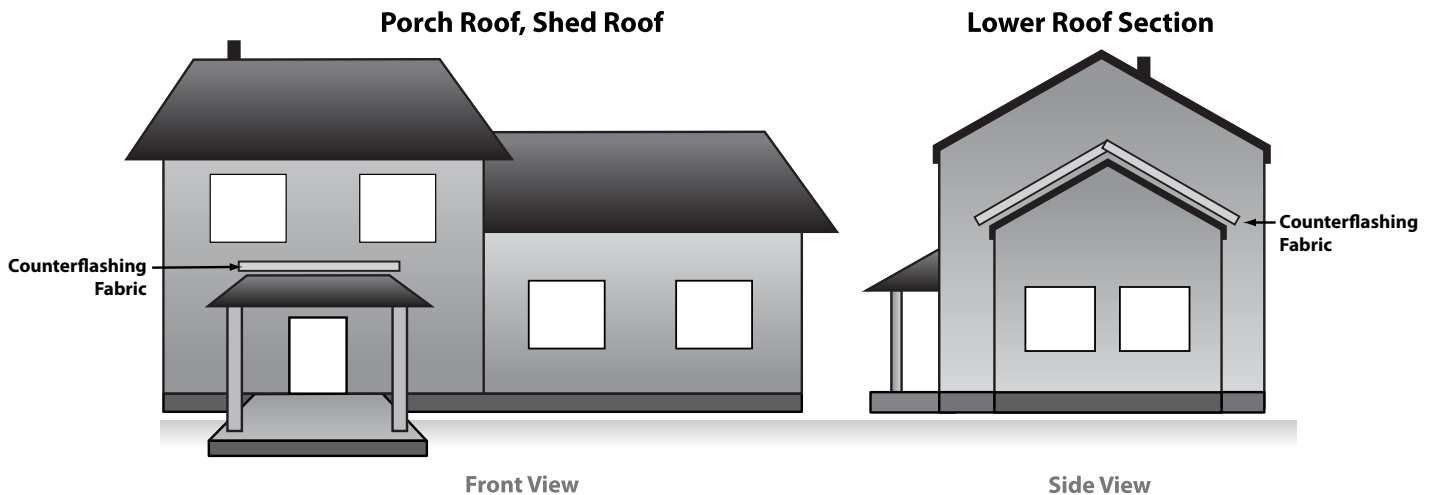

**3.** Detail window and door openings per the following procedure.

- A. The upper portion of the Enviro-Dri Counterflashing Fabric is embedded in the Enviro-Dri Field Membrane
- B. Enviro-Dri Joint Fabric is installed on both jams and sill of window openings. The coated Enviro-Dri Joint Fabric will extend from the interior the opening outward to the outside edge of the sheathing and wrapped onto the exterior surface 0" to 1" depending on the quality of the sheathing.
- C. TBS recommends the installation of an outward sloping wedge on the sill prior to installing and coating the Enviro-Dri Joint Fabric and or Sill Flashing.
- D. Any portion of the sill/jam intersection not covered with Enviro-Dri Joint Fabric must be sealed with Enviro-Dri Joint Sealant or other TBS approved sealant.
- E. An 8" width of vinyl-backed butyl rubber is installed as shown, covering the entire sill extending 2"-4" down onto the outer wall surface and onto the side wall surfaces.

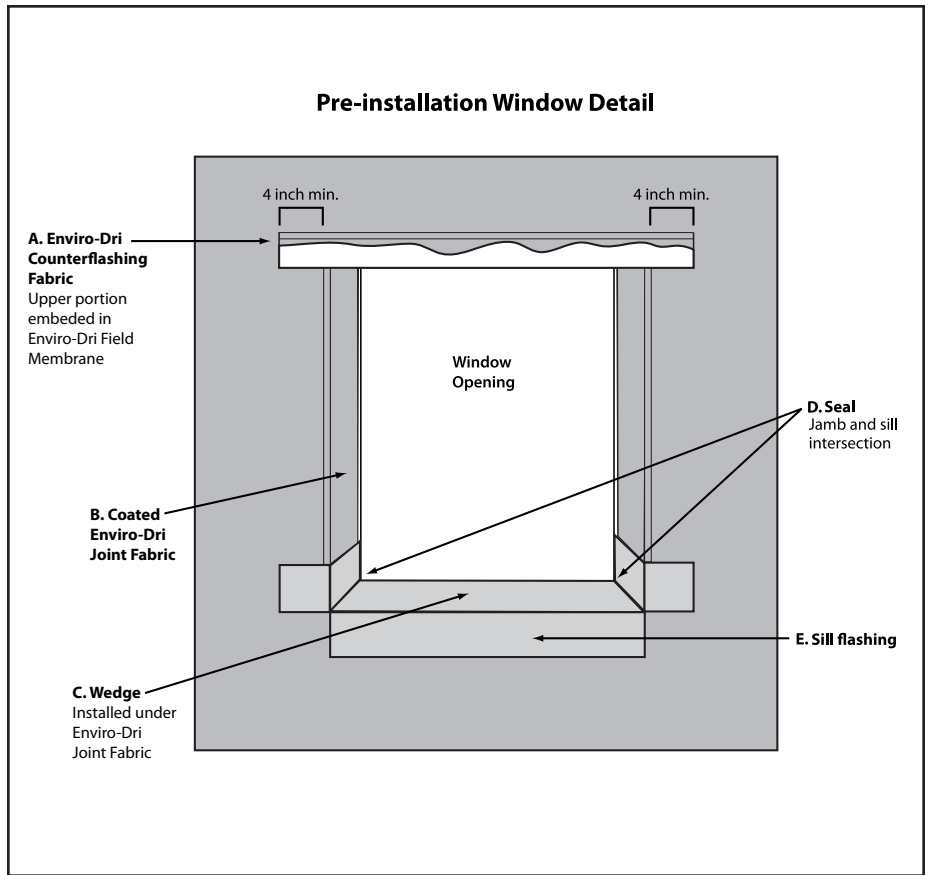

**4.** Enviro-Dri Counterflashing Fabric shall be installed over the top of all window and door openings with the bottom edge of the Enviro-Dri Counterflashing Fabric aligned with the top edge of the opening. The Enviro-Dri Counterflashing Fabric shall extend a minimum of 4" beyond the vertical edges of the opening onto the sheathing surface.

